

MICROTEL D51T

Microtel D51T

Operating Manual

14 September 2009

Rev. A

Proprietary Notice: This document and the subject matter hereto are the property of **MICROTEL**, Inc. and shall not be reproduced or copied or used for the purpose of manufacturing or sale of apparatus, except by written permission of **MICROTEL**.

MICROTEL

11725 Sunbelt Court
Suite C
Baton Rouge, LA 70809
225-303-0436
Fax: 225-303-0568
www.microtel-inc.com

TABLE OF CONTENTS

INTRODUCTION	2
CHAPTER 1 - DESCRIPTION OF THE <i>D51T</i> DIALER	4
CHAPTER 2 - INSTALLATION	8
Quick Start Procedure	11
CHAPTER 3 - OPERATION	13
Configuration	14
Basic System Information	14
Configuring Fault Inputs	16
Telephone Numbers	18
Operations	18
Alarm Acknowledgment	19
Checking System Status	19
Controlling the local output relay	20
CHAPTER 4 - MAINTENANCE/TROUBLESHOOTING	21
CHAPTER 5 - ADVANCED TOPICS	23
Advanced Configuration Options	23
APPENDICES	25
APPENDIX A: Technical Specifications	25
APPENDIX B: Glossary of Dialer Terminology	28
APPENDIX C: FCC Requirements	29
APPENDIX D: <i>D51T</i> Command Summary	30
APPENDIX E: Mechanical Dimensions	31

LIST OF ILLUSTRATIONS

Figure 1: Controls and Indicators	3
Figure 2: Power Supply Connection	8
Figure 3: I/O Terminal Connections	10
Figure 4: Mounting dimensions	30

INTRODUCTION

Thank you for choosing the Microtel *D51T* Dialer to implement your remote digital and temperature alarm monitoring solution. You have chosen a product that is simple to set up and easy to use. *D51T* has been designed and manufactured to operate with minimal operator intervention.

The Microtel *D51T* features a single level, interactive command structure--there are no multi-level menu structures to navigate. Commands are sent to the dialer through your telephone either locally or during a call to or from the dialer, by pressing a sequence of touch-tones on your telephone. Each command entered is acknowledged with a spoken response from *D51T*, providing verification that the command was entered correctly and understood by the dialer.

About this Manual: This manual is organized with the most crucial information in the front; more advanced topics are saved for last or included in the appendices.

Who Should Read this Manual: Anyone involved with use of the dialer should read the *General Description* and *Operation* chapters of the manual. The *Operation* chapter in particular should be read by any personnel who may be required to respond to alarm calls from the dialer. The additional chapters can be read at a later time, or when necessary by authorized personnel to maintain the dialer or troubleshoot any problems you might encounter. System administrators should read the *Advanced Topics* chapter for information on the use of the dialer's remote software configuration capabilities.

In a Hurry to Setup? Read the Quick Start section of the *Installation* chapter.

If you encounter a difficulty that cannot be resolved using the information in the manual, call **MICROTEL** at (225) 303-0436.

Again, thank you for choosing **MICROTEL**.

MICROTEL D51T

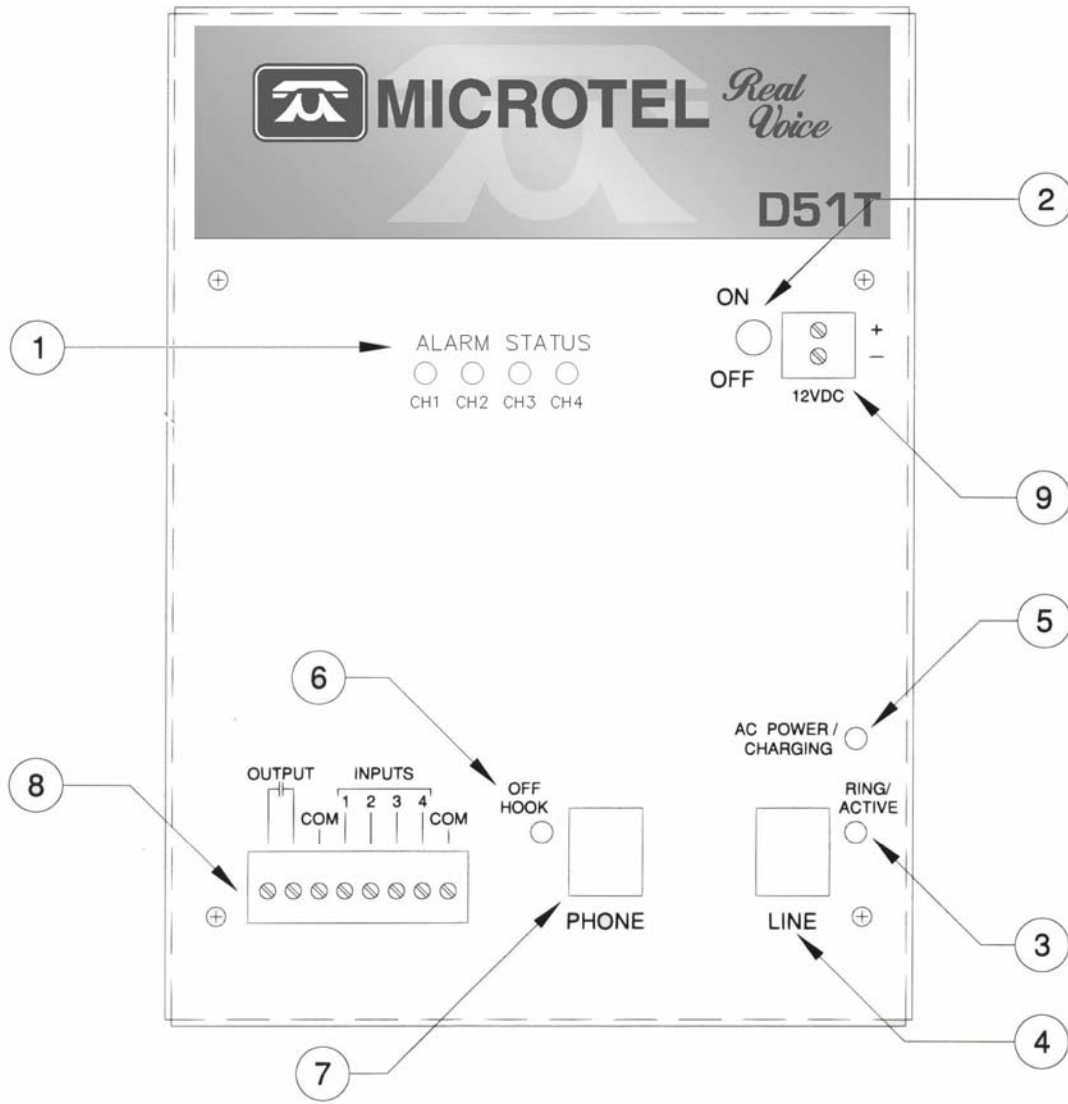

Figure 1: Controls and Indicators

CHAPTER 1 - Description of the *D51T* Dialer

The *D51T* is a small, rugged, and simple, but powerful, device which easily handles complex dialing notification and alarm monitoring. To accomplish these tasks, *D51T* has an equally simple operator interface. Figure 1 illustrates the controls and indicators of the dialer, and the following paragraphs describe them.

(1) **FAULT LEADS** in the upper middle indicate status for each of the four input channels:

GREEN (Steady) = Normal.

GREEN (Flashing) = Input returned to normal state, but is not yet acknowledged.

YELLOW = Input is in fault state, but alarm delay has not yet elapsed.

RED (Flashing) = Input is in unacknowledged alarm state.

RED (Steady) = Input is in acknowledged alarm state.

(2) **ON/OFF SWITCH** located in the upper right corner, turns the dialer on or off.

(3) **RING/ACTIVE LED** located adjacent to the LINE connector indicates call progress while the dialer is off-hook and incoming ring detection when on-hook.

(4) **LINE JACK** is a standard RJ11 phone jack where an outside line is connected to the dialer.

(5) **AC POWER/CHARGING LED** indicates that external power is present and is charging the internal, standby battery

(6) **OFF HOOK LED** located adjacent to the PHONE connector is turned on whenever the dialer senses that a telephone connected to the phone jack is off-hook, and *D51T* is ready to accept programming commands.

(7) **PHONE JACK** is a standard RJ11 phone jack used to connect a local phone--used for entering programming commands--to the dialer.

(8) **I/O TERMINAL BLOCK** is used to wire external sensors to the dialer, and also provides the local alarm contacts to external equipment.

(9) **12 VDC TERMINAL BLOCK** for connecting 12 – 20 VDC Power.

How Does the Dialer Work? This section provides a simple theory of operation by asking a few questions about typical use of the dialer. The following paragraphs assume the dialer is hooked up and running as described in the *Installation* chapter. The *Operation* chapter provides the details that are missing from the discussion below.

What Happens when an Alarm Occurs? D51T has a telephone directory of up to four people, answering machines, or pagers to call in the event of an alarm. When an alarm occurs, the dialer begins to place a series of telephone calls in an attempt to have someone acknowledge the alarm.

The dialer reports the current alarm status when an outgoing call is answered. It repeats the message several times while listening for a touch-tone being entered on the remote phone.

How does an Alarm get Acknowledged? An alarm can be acknowledged in three ways:

- 1) Entering the '*' key on your touch-tone phone during message playback.
- 2) Calling back the dialer immediately after it calls you (callback acknowledge). This feature is necessary if the called party does not have a touch-tone phone.
- 3) The dialer will automatically acknowledge a successful call to a pager, answering machine, or P.A. system if the telephone number is embedded with an auto acknowledge code. (See chapter 5, *Advanced Topics*).

What if I'm not Home? The Call Progress Decoding features of the dialer allow it to determine if the called telephone number is busy or did not answer. In either case, the dialer will wait 10 seconds before going off-hook and placing a call to the next number on the calling list.

When the dialer is off-hook, it has the capability to detect dial tone, busy, ringback, and voice signals. This allows it to detect if a called party answered or not, thus reducing the time to alert authorized personnel of existing alarm conditions. If a call is not answered, or the called number is busy, the dialer will abort the call and begin calling the next number on the system telephone list.

Will the Dialer Call Me Back? Maybe. The dialer has a snooze timer. When an alarm is acknowledged, the snooze timer is started, and alarm calls for all acknowledged faults are suspended. If a channel is still in alarm after the snooze period ends, then the dialer will begin a new alarm dialing sequence (starting with the first number on the telephone list).

How does the Dialer Know Who to Call? The dialer has a System Telephone Directory composed of up to four user-programmed telephone numbers. Each telephone number in the System Telephone Directory can be up to 30 digits long. Special '*' control sequences may be embedded within a user-programmed telephone number.

These include tone/pulse selection dialing, pauses, auto acknowledgment of an alarm call-out, dial '*' or '#' for interfacing to telephone equipment. These special sequences allow a tremendous amount of flexibility on a telephone number by number basis.

How does the Dialer Prioritize its Calls?

When the dialer detects a new alarm condition, it will search the telephone directory, beginning with the *first* number on the list, for the first valid telephone number. The dialer will then go off-hook and begin to dial the telephone number if the following conditions are true:

1. The Call Spacing Timer = 0, and the dialer has been on-hook for at least the network recovery time (10 seconds).
2. The local telephone is on-hook (OFF HOOK LED is OFF).
3. The telephone line is operational (dial tone is detected).

During the dial out sequence, the dialer will implement all special control sequences and/or call progress features embedded within the current telephone number. If the dialer successfully connects with the called number, it will report the verbal alarm message for each fault condition which exists.

The dialer will repeat the alarm message Five times after a call is answered. While speaking the alarm message, the dialer simultaneously listens for a touch-tone entered by the user at the remote phone. If it receives a valid tone, it will terminate alarm reporting, and examine the tone received. If the user entered a '*' key, the dialer will accept it as an acknowledgment of the alarm condition. Any other keys received will *not* acknowledge the alarm condition. The dialer will then indicate the acknowledge status and prompt the user to enter a 2-digit access code.

If the user enters the correct code, access will be granted and the user may review or program the dialer's configuration using the touch-tone commands described in this manual. If at any time during remote menu access the user does not enter a command within 30 seconds, the dialer will speak a disconnect warning and hang up.

If an incorrect or no access code is entered during a timed access code entry time (10 seconds), the dialer will disconnect and initialize the system Call Spacing delay timer. If the alarm condition(s) were acknowledged, then the snooze timer(s) associated with the reported alarm condition(s) will be initialized with a value equal to the programmed system Snooze Delay. If alarm conditions were not acknowledged, calls will continue to be placed to the next telephone numbers on the list after the system Call Spacing delay has expired.

How can I Make an Alarm Sound in the Vicinity of the Dialer?

The local summary alarm contacts will be *de-energized* (opened) whenever a fault condition exists. This output could be connected to an interposing relay whose contacts would be used to switch a siren or bell to warn the local area of the alarm condition.

CHAPTER 2 - Installation

Installation of the *D51T* involves several, simple steps. This chapter outlines the physical connections to the dialer. At the end of this chapter is a Quick Start procedure which summarizes the configuration procedure of the dialer.

Step One - Connect the Power Supply Connect the supplied external transformer to the 12 VDC terminals as shown in Figure 2 below. Plug the transformer into a MicroMax Surge Suppressor (Recommended by Microtel).

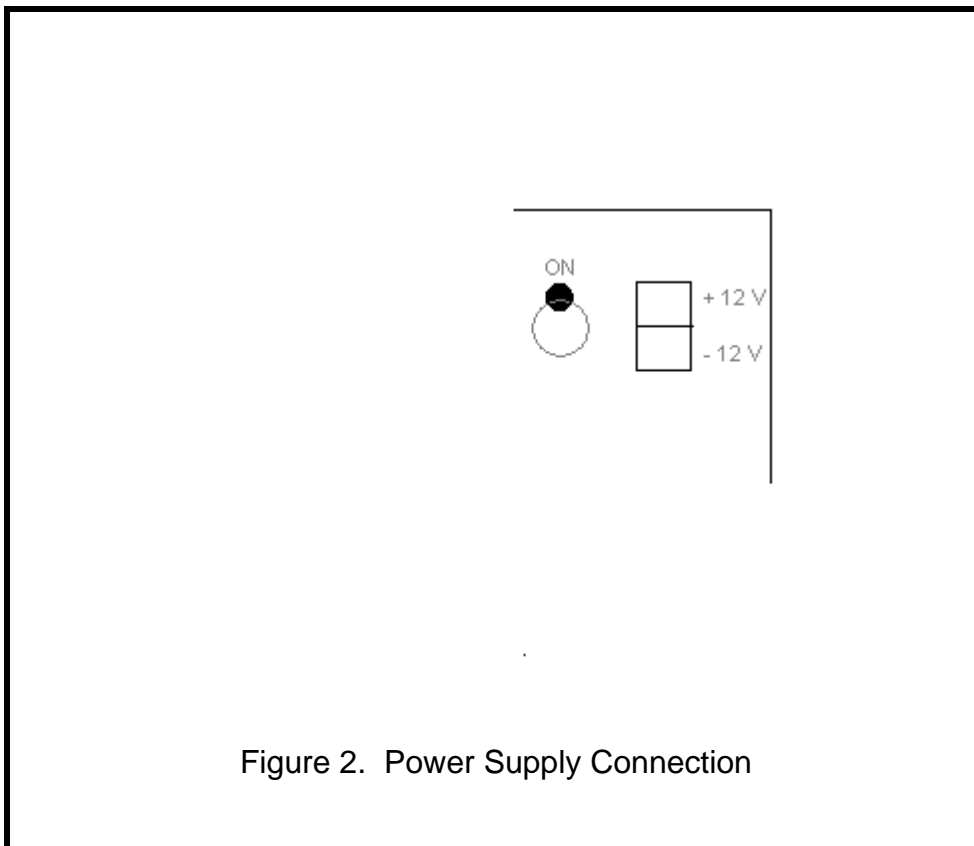

Figure 2. Power Supply Connection

NOTE: Alternatively, you may connect any 12 to 20 Volt DC power (such as a solar panel) to the dialer. Connect the positive side of the voltage source to 12VDC+, and the COMMON lead to 12VDC- of the power supply terminal block of the dialer.

NOTE: Although the dialer will operate and place telephone calls when operating on its standby battery, external power **must** be present whenever you wish to configure/query the dialer from the local phone PHONE jack.

Step Two - Telephone Connections include the external phone line for call-outs and the optional local telephone connection for local programming and monitoring.

CAUTION: This equipment cannot report an alarm when other equipment (telephone, answering system, computer modem, etc.) connected to the same phone line is in use.

1. Connect the dialer's LINE jack to the EQUIPMENT Phone jack of the MicroMax Surge Suppressor using the cable supplied with your dialer.
2. Connect the Telephone LINE jack on the MicroMax Surge Suppressor to the RJ11 jack of your outside line using the cable supplied with the MicroMax Surge Suppressor.
3. Connect a local telephone (optional) to the dialer's PHONE jack.

NOTE: Telephone line transients and surges can damage the dialer or disrupt its operation. We recommend use of the MicroMax Surge Suppressor for normal operations.

Step Three - Connect External Input/Output to the Dialer Each Fault input has a corresponding terminal (1 - 4), and there are two COM terminals. See Figure 3

MICROTEL D51T

below. The terminals are large enough to accept two 14 AWG wires, so if more than two faults are wired, the COM terminals must be shared. The fault sensing circuitry is transformer and optically isolated from the dialer circuitry, but all faults share the same COM. Use 22 AWG shielded twisted pair wire when wiring external sensors to the I/O terminals. Whenever possible, ground the shield at the sensor end only. Sensor control wires should never share conduit with AC power wiring.

The local alarm contacts are normally energized, and closed. When a user-defined alarm condition exists these contacts are opened (de-energized). These contacts may be used to drive a low power (10 volt-amps Max.) resistive load, or as a signal to another piece of process-monitoring equipment. High power and/or inductive loads must be driven from an external power relay. The local alarm contacts are suitable for driving a 12 – 48 volt DC relay coil.

NOTE: Keep I/O runs to a maximum length of 150 ft.

NOTE: There is an onboard temperature sensor used for the Low and High Temperature Alarms.

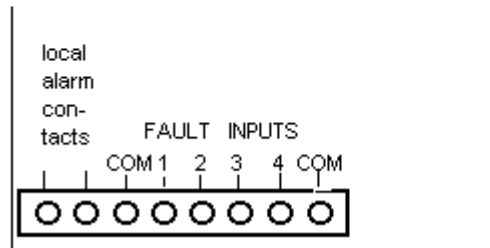

Figure 3. I/O Terminal Connections

Quick Start Procedure

This procedure outlines the steps to get the *D51T* dialer operating in a typical manner with a minimum of programming.

1. Plug the touch-tone telephone into the Dialer PHONE jack.
2. Connect external 12 VDC transformer to dialer power supply terminal block.
NOTE: External power is required in order to configure the dialer from a local phone.
3. Verify that the AC POWER/CHARGING LED illuminates (green).
4. Turn ON the dialer switch. Take the telephone off-hook. The OFF HOOK light should be illuminated (red) indicating the unit is ready to accept touch-tone commands from the local telephone.
5. Press the # key of your telephone. The Dialer will respond “Ready.”

NOTE: To start over, press the # key and listen for *D51T* to speak, “Ready.”

6. Enter Telephone Numbers to Call upon Alarm.
 - Enter ****8np****, where n = 1, 2, 3 or 4 is the dialer’s directory index of telephone numbers, and p is the actual telephone number (including optional escape codes of up to 60 digits). Example: The second phone number of the directory is 555-1212. Enter ****82 5551212****.
 - The Dialer will respond, “Telephone number two is 5551212.”
7. Configure Input Normal States
 - Enter ****c3n**, where c is the I/O channel (numbered 1 to 4 from left to right) and n = 1 for NORMALLY OPEN, or 0 for NORMALLY CLOSED.
8. Record System and Alarm Voice Messages

System ID Voice Message:

 - Enter ****01** to record up to a 10 second system voice message. The dialer will respond “Ready”.
 - Speak your message clearly into the handset.
 - The dialer will speak back the message after the 10-second recording interval.
 - Repeat as necessary until you are satisfied with the recording.

MICROTEL D51T

Individual Channel Alarm Messages:

- Enter **c1 to record an alarm message for a specific I/O channel. (c = 1 to 4 for the I/O channel of interest). The dialer will respond “Ready”.
- Speak your message clearly into the handset.
- The dialer will speak back the message after the 6-second recording interval
- Repeat procedure for the next I/O channel and message.

9. Verify Configuration Data is saved in the Dialer.

Turn OFF the Dialer’s power switch, wait a few seconds, then turn it ON again. Verify configuration data has not changed. By entering *00 and listening to the spoken status report.

10. Important: Test the dialer by causing an alarm condition. Verify ALL the programmed telephone numbers are successfully called in order to ensure the dialer is operating properly and can successfully report an alarm condition. Periodically, retest to continue to ensure the dialer is operating correctly.

WHEN PROGRAMMING EMERGENCY NUMBERS AND(OR) MAKING TEST CALLS TO EMERGENCY NUMBERS:

- 1) Remain on the line and briefly explain to the dispatcher the reason for the call.
- 2) Perform such activities in the off-peak hours, such as early morning or late evenings.

CHAPTER 3 - Operation

This chapter, divided into Configuration and Operation sections, will explain how to configure the *D51T* to react to I/O events and how an operator can make the dialer respond to remote commands. The Microtel *D51T* features a single level, interactive command structure--there are no multi-level menu structures to navigate. Commands are sent to *D51T* through your telephone either locally or during a call to or from the dialer, by pressing a sequence of touch-tones on your telephone. Each command entered is acknowledged with a spoken response from the dialer, providing verification that the command was entered correctly and understood by the dialer.

All programming commands (commands that modify dialer configuration or cause an action to occur) begin with ‘**’ (two stars). All review (report) commands begin with a ‘*’ (single star). After each command is entered, the dialer will respond with a voice message. Most commands require exactly the same number of keys every time, but some commands have a variable data length. The end of variable length data commands is performed with the ‘**’ (two stars).

NOTE: An unwanted command can be terminated at any time by pressing the ‘#’ key. The dialer will respond, “Ready”, indicating it is ready to accept a new command.

Throughout this manual, all commands are highlighted for quick reference as follows:

*nn	Review item
**nidd	Configure item

If your telephone line is not yet installed, you can still configure your dialer:

1. With power to the dialer off, connect the telephone to dialer’s PHONE jack.
2. Take the telephone off-hook.
3. Turn ON power to the dialer (external 12 VDC power required)
4. The telephone should now be connected to the dialer (indicated by the OFF HOOK LED being ON).
5. You may now enter any of the touch-tone commands to query/configure the dialer.
6. When you are finished, hang-up. The OFF HOOK LED should turn OFF indicating that you hung-up.

Configuration

The configuration commands described in this section modify basic dialer operation and store information about the dialer's operational behavior in nonvolatile memory. You should only have to configure your dialer once -- all changes are saved permanently, even if AC and battery power are removed from your dialer. This section consists of the following subsections:

- Basic System Information - Set/Query various system values
- Telephone Numbers - Set/Query each of the outgoing phone numbers
- Fault Inputs - Set/Query the Fault Input configurations and Low and High Temperature Setpoints.

The following abbreviations are used in the manual to represent user-selected inputs in the Dialer configuration commands:

Abbreviation	Meaning
c	Fault Input Channel Number, 1-7 (5 = power-fail; 6,7 = Temp Alarms)
~	Recorded speech
n	1 digit numeric data
nn	2 digit numeric data
p	Variable length Telephone number (up to 30 digits) with escape codes

Basic System Information

The following commands configure and report the current values for the system level information of the D51T. A Glossary of Dialer Terminology that defines these parameters with respect to D51T operation is provided in the Appendix B.

- **Voice System Name** The message the dialer will speak before making any report.

*01	Play system name
**01~	Record system name

Once the command to Record the system name has been typed in, the dialer will speak "Ready" as a prompt for you to begin speaking. Speak the message up to 10 seconds in length. When finished the dialer will play back for your review.

Example voice responses-

Jonesburg remote site number 6 (recorded)

MICROTEL D51T

- **Answer Delay** The number of rings the dialer will see before answering an incoming call.

*02	Review answer delay
**02nn	Program answer delay

Example- Command: **0205
Response: *The answer delay is zero five.*

- **Access Code** This 2 digit access code is required to access configuration commands during a telephone call to or from the dialer.

*03	Review value of access code
**03nn	Program access code

NOTE: The factory set default code is '12'. Use a 00 access code value to disable access code requirement. Access code is not required to configure the dialer through the local PHONE jack.

Example- Command: **0313
Response: *The access code is one three.*

- **Snooze Delay** The snooze delay is the time, in hours, after which the dialer will re-arm an acknowledged alarm and begin calling again as a reminder that the alarm condition still exists.

*04	Review snooze delay time interval
**04HH	Program snooze delay time interval

Example- Command: **0412
Response: *The snooze delay is one two.*

- **Firmware Version**

*05	Report Firmware Version
-----	-------------------------

Response will play back all resident vocabulary, then Speak "Number 10", where 10 is the current Firmware version.

Configuring Fault Inputs

The *D51T* features true modularity—Fault input channels operate completely independently of each other. Using the following commands, each Fault Input in your dialer can be configured to operate uniquely to satisfy your application requirements. For each Fault Input, record a voice message, program an alarm integration delay, define the input channel's normal (non-alarm) state, and configure whether cleared alarms should be reported. Channels 6 and 7 are the Low and High Temperature Alarms, respectively. Each of these can be Enabled/Disabled and configured with a setpoint from 00 to 99 degrees Fahrenheit.

- **I/O Channel Voice Name** An individual I/O channel's spoken voice name.

*c1	Play I/O channel c voice name
**c1~	Record I/O channel c voice name

NOTE: User cannot record a voice message for the Power Fault channel 5

Sample Message- *Channel one normally open digital input.*

A new channel name can be recorded with the '*c1' command. Once the command is typed record your voice message after the dialer prompts you "Ready". A maximum of 6 seconds of recording time is allowed for each fault input message.

- **I/O Channel Fault Delay** When channel *c* changes state, this timer delays an alarm until the channel has been in the alarm state for this many seconds (SS). This parameter will filter out noisy, or temporary, state changes from placing undesired nuisance alarm calls.

*c2	Report I/O channel c delay
**c2SS	Program I/O channel c delay

Example- Command: **1230
Response: *Channel one fault delay is three zero.*

- **I/O Alarm Configuration** Selection of channel *c* normal state (OPEN or CLOSED)

*c3	Review I/O channel c alarm configuration
**c31/0	Program I/O channel c alarm configuration

Example- Command: **131
Response: *Channel one normal state is open*

MICROTEL D51T

Example- Command: **430
Response: *Channel four normal state is closed*

NOTE: If C=5, the Power Fault channel, the response is:

Example Command: **531
Response: *Power fault channel is READY*
Command: **530
Response: *Power fault channel is OFF*

NOTE: When channel 5 is configured OFF it will not call out when a power failure occurs.

- **I/O Return-To-Normal Status** Selection of channel **c** return to normal status notification. When enabled, the input channel's return to a normal state after an alarm will cause a notification callout, using the same list of telephone numbers to call as an alarm event.

NOTE: Unlike Alarm events, once acknowledged there is NO snooze operation.

*c4	Review I/O channel c return-to-normal configuration
**c41/0	Program I/O channel c return-to-normal configuration

Example- Command: **141
Response: *Channel one alarm clear status is enabled.*

Example- Command: **440
Response: *Channel four alarm clear status is disabled.*

- **I/O Alarm Setpoint** Selection of Low or High Temperature Alarm Setpoints. Channel 6 is the Low Temperature channel, and Channel 7 is the High Temperature channel. The following command allows the Low or High temperature alarm Setpoint to be configured or queried.

NOTE: This command is only valid for c = 6 (Low Temperature) or c = 7 (High Temperature).

NOTE: The Low and High Temperature Alarms must be ENABLED using the **c31/0 I/O Alarm Configuration command defined above.

*c5	Review I/O channel c Alarm Setpoint
**c5nn	Program I/O channel c Alarm Setpoint

Example- Command: ** 6 5 39
Response: *The low temperature alarm point is three nine degrees.*

Example- Command: ** 7 5 90

MICROTEL D51T

Response: *The high temperature alarm point is nine zero degrees.*

Example- Command: **** 1 5 90**
Response: *Error!*

(Error! is spoken by the dialer because Channel 1, a digital input, does not have an alarm set point).

Telephone Numbers

As described in the theory of operation in Chapter 1, *D51T* can store up to four (4) phone numbers in the System Telephone Directory. This section explains how to program the dialer's telephone numbers and shows how to customize the numbers for certain call-out situations.

Use the following command to enter each telephone number into *D51T*:

*8n	Review Telephone n (n=1 to 4)
8np	Program Telephone n (n=1 to 4)

p = telephone number of up to 30 digits with escape codes for one of 4 (four) telephone numbers. The telephone data is terminated with ****** (two asterisks).

Example- Command: ****812760571****
Response: *Telephone number one is two seven six zero five seven one*

Example- Command: ****852432400****
Response: *Telephone number five is two four three two four zero zero*

These phone numbers may be customized to use the Call Progress features of the dialer. Refer to the *Advanced Topics* chapter for a full discussion about using these powerful features of the *D51T* Dialer.

Operations

MICROTEL D51T

This section details operation of the dialer, from both local and remote locations. Sections will detail the following actions:

- Alarm Acknowledgment
- Checking System Status
- Controlling the local output relay

Alarm Acknowledgment

When *D51T* calls you, you may wish to respond to the call differently depending on what type of alarm has occurred, who is on duty, the time of day, severity of the alarm, etc.

If you wish the dialer to go to the next phone number on its calling list, hang up the phone. The dialer will continue on after the call spacing delay to the next phone number on the list until it receives an acknowledgment or the unlatched alarm goes away by itself.

If you wish to acknowledge the call from your touch-tone phone, press the “*” key on your telephone *while* the alarm message is being spoken. The dialer will respond by reporting that the alarms are acknowledged. If you then need access to the remote programming commands, enter the 2 digit access code when *D51T* prompts you. After gaining access to the dialer, you may review or modify any of the dialer’s configuration data.

NOTE: If you don’t have a touch-tone phone, you can acknowledge the alarm call by hanging up the phone and calling the dialer back within the call-spacing period (One minute). When the dialer answers the telephone call, all fault conditions will be acknowledged.

Checking System Status

D51T allows for easy checking of system status and capability. Spoken reports of your entire dialer-monitored system can easily be generated.

A spoken system status report can be received from the dialer by entering the following command from a touch-tone telephone either locally, or remotely after answering or calling the dialer: The dialer will speak a voice message of system name and current alarms or normal status. It will also report the current temperature and local output state IF the local output has been manually controlled.

- **System Status** Gives a complete status of all points monitored by the dialer

*00	Report system status
-----	----------------------

MICROTEL D51T

Example- Command: *00
Response: *Channel one normally closed digital input in alarm. Temperature is seven eight degrees. The local output is open.*

Controlling the local output relay

D51T has a set of output contacts that may be controlled from a touch-tone phone. These contacts may be used to turn ON or OFF external equipment, or as a signal input to another device. Simply enter the following command during a phone call to or from the dialer, via either the phone or cellular connection.

NOTE: *de-energized* state is open.

*06	Review local output configuration
**06 0/1/2	Configure/Control local output

Example- Command: **060
Response: *The local output is closed.*

Example- Command: **061
Response: *The local output is open.*

Example- Command: **062
Response: *The local output is fault status*

CHAPTER 4 - Maintenance/Troubleshooting

The *D51T* Dialer is built to require minimal maintenance. Only the system battery requires your attention from time to time for your dialer to continue performing with no problems.

INTERNAL RECHARGEABLE BATTERY: A battery in typical standby use will last approximately 2 to 4 years. Battery life is mostly dependent upon the number of power outages sustained and the age of the battery, and temperature. A new battery should take no longer than 72 hours to gain full charge, capable of powering the system through a power outage of greater than 24 hours. Battery backup time may vary depending upon the age of the battery and the frequency and duration of alarm callouts which occur while the dialer is operating on the standby battery.

FUSE: *D51T* features an internal, resettable fuse which never requires service. If you can measure 12 – 20 VDC at the external power input terminal block, but the AC POWER/CHARGING LED is OFF, the fuse may have blown. Remove power from *D51T* by turning OFF the Power switch and unplugging the removable External Power Terminal Block. Wait for about a minute for the fuse internal to the dialer to cool down, then plug the power back in. If the AC POWER/CHARGING LED comes ON briefly then goes OFF, the fuse is blowing. Blown fuses can be indicative of other problems. Measure the input power supply, and verify that it is 12 – 20 VDC. A high external voltage may cause the fuse to blow. If the fuse continues to blow and the external power is within specifications call the factory.

TROUBLESHOOTING:

- Symptom:** Unable to place telephone calls (Line LED comes on but no ring at called telephone number).
- Cause: Phone number not entered correctly.
 - Cause: Call being placed to different number than expected.
 - Cause: Phone line not plugged-in, phone line broken or in use.
 - Cause: No touch-tone service, use pulse method by pre-pending *1 to each phone number
- Symptom:** Unable to program with local telephone.
- Cause: External 12 VDC power required. (Green AC power/charging LED must be on)
 - Cause: Incorrect command format (all commands begin with * or **). To clear out the message buffer at any time, press the '#' key.
 - Cause: Touch-tone phone must be used (listen for tones when keys are pressed).
 - Cause: Phone not plugged in correctly (local telephone must be plugged into PHONE jack, and OFF HOOK LED should be on).
 - Cause: Dialer off-hook placing call (RING/ACTIVE LED is on).
 - Cause: Very loud or noisy environment -- program from remote phone or use a mute button on the local phone.
- Symptom:** Not placing alarm call (RING/ACTIVE LED does not come on).
- Cause: Fault input not really in alarm or is not a new alarm. FAULT LED should blink.
 - Cause: Alarm delay is too long. Try setting a shorter Fault Delay period.
 - Cause: Local telephone is off-hook. Is OFF HOOK LED ON? This halts the dialer.
 - Cause: Intercall (Snooze or Call-spacing) delay set. Dialer waits before next call.
 - Cause: No telephone numbers to call. Review telephone numbers.
- Symptom:** Dialer is dead (AC POWER LED is off).
- Cause: Check power to dialer. Make sure it is wired properly.
 - Cause: No external power and internal battery is dead.
- Symptom:** Dialer is dead (AC POWER/CHARGING LED is ON, Power switch is ON)
- Cause: Review all System and Fault Input configuration, and Telephone Numbers. Nonvolatile data may have been corrupted, not entered, or incorrectly entered. Enter *00- The dialer will recite the status of the dialer then "Data Error" indicating corrupted nonvolatile parameters.

MICROTEL D51T

Example 2- Program phone number 8

				Pulse dial the following digits
				Dial phone number 5551212
				Terminate
Command				
	**88	*1	5551212	**

Response: *Telephone number eight is STAR one five five five one two one two*

- **Reduced power operation** D51T's already low power consumption can be reduced 33% for installations providing minimal power, such as solar panels. To enable reduced power mode enter the following command:

**054	Toggle normal/low power mode
-------	------------------------------

Example- Command: **054
Response: *Low power enabled.*

Example- Command: **054
Response: *Normal power enabled.*

Each time the command is entered, the power mode toggles between normal / low power modes. Visually, this is indicated by a reduced duty cycle of the four (4) ALARM STATUS LEDs: in low-power mode, the LEDs flash very briefly once a second; in normal mode the LEDs are mostly ON, but briefly flicker OFF once a second.

In addition to configuring the dialer to operate in low-power mode with this command, power consumption can be reduced even more by de-energizing an unused local alarm output.

Example- Command: **061
Response: *The local output is open.*

This will reduce current consumption of the dialer by an additional 10 milliamps. Use this additional option if the local relay output is not being used as a summary alarm output or to control external equipment.

APPENDICES

APPENDIX A: Technical Specifications

A.1 Communications

Phone Interface:	ACTA ID: 7AAAD00BDS65616 For connection to PSTN or Cellular network via Cellular Interface.
Ringer Equivalence Number:	0.0B
LED Indicators:	Dialer Active/Ring Detect/Call Progress Local Telephone Off-hook/Ready to program Fault/Normal status for each input channel Low-power/battery operation indication AC Power/Charging
Dialing Capacity:	4 Phone Numbers, 30 Digits Each Tone or Pulse Dial Special Sequences for Selection of Pulse/Tone, Pause, Pagers, Auto-Acknowledging Alarms.
Call Progress Detection	Dial Tone Detect Busy Detect Ring Back/No Answer Detection
Answer Delay:	1-99 Rings (Call Back Acknowledge)

A.2 Electrical

Input Power:	Plug in Wall Power Supply, 120 VAC to 12 VDC UL/CSA approved. or 12-20VDC @ 0.5 Amp Solar Power Interface Compatible On/Off Switch Internal Battery-charging circuit AC Power/Battery Charging Indicator Resettable Internal Fuse Optional: Micromax Surge Suppressor
Battery Operational:	Rechargeable 6-AA cells NiCad Battery Pack (24 hour standby, 6 hour active calling, typical)

MICROTEL D51T

A.3 Environmental

Temperature: 20°F to 122°F operating
0°F to 130°F storage

Humidity: 0-95% RH, Noncondensing

EMI/RFI: Per FCC Part 15 Class A

A.4 Enclosure

Options: Panel Mount Chassis
(7.7" wide 8.8" high x 4" deep)
Suitable for Wall or Panel Mounting
Battery Mounted Separately
Nema 4 Fiberglass Case with Hard Cover
(12" Wide, 15.5" High, 6.6" Deep)
Nema 12 Fiberglass Case with Hard Cover
Nema 12 Fiberglass Case with Clear Cover
(9" Wide, 10.5" High, 6.5" Deep)

Weight: Panel Mount Unit 4 lbs
Nema 12 case: 6 lbs
Full system: 10 lbs

A.5 Speech

Type: Nonvolatile, better-than-telecom quality, with Automatic Gain Control of user-recorded messages.

Resident vocabulary for programming prompts, and User-Recorded Messages for System Greeting and each Fault Input.

Recordable Message Lengths: 10 Seconds System Message
6 Seconds Each Fault Message

A.6 Fault Inputs

Type: Isolated Dry Contact, Normal Open or Normal Closed, Non-Latched, optional Alarm-Clear.

Sensing frequency: 1 Hz

Sensing current: Closed circuit sees a 10 mA (nominal), 10 millisecond-duration pulse, once every second.

MICROTEL D51T

Sensing voltage:	Open circuit sees 5 Volts (nominal)
Max. Loop Resistance:	10 killohms
Max. Loop Capacitance:	100,000 picofarads
Isolation:	1500 Volts, transformer and optical isolation.
Fault Integration Delay:	00 – 99 seconds
AC Power Fail Detect:	Internal circuit, configurable enable and alarm delay

A.7 Temperature Measurement and Alarms

Type:	Onboard, internal to the enclosure, temperature IC
Accuracy:	+/- 5 degrees Fahrenheit
Reporting Resolution:	1 degree Fahrenheit
Low Temperature Alarm:	Setpoint 00 to 99 degrees Fahrenheit
High Temperature Alarm:	Setpoint 00 to 99 degrees Fahrenheit

A.8 Local Summary Alarm Contacts

Type:	Relay, Type 1A Contacts
Operation:	Normally energized (contacts closed), De-energized (contacts open) when a Fault condition is present; or, manual control of output contacts via DTMF command.
Contact Rating:	10 VA, Resistive Load
Max. Switch Current:	0.5 Amp D.C
Max Switch Voltage:	48 Volts D.C.
Max. Carry Current:	1.25 Amps D.C.
Isolation:	1500 Volts

APPENDIX B: Glossary of Dialer Terminology

Acknowledge	Stops the dialer from placing additional calls concerning an alarm condition. Acknowledgment can be made by entering the '*' during alarm playback, with call-back acknowledge, or by an auto acknowledge phone escape sequence (*4) embedded within the telephone number.
Alarm condition	An event detected by the dialer usually causing a phone call.
Return-To-Normal	A configurable option for each input that causes an alarm callout sequence when a Fault condition clears.
Call-spacing	The time delay between successive answered, but unacknowledged telephone calls.
Intercall delay	Same as Call-spacing.
I/O channel	A dialer to outside world connection.
New alarm	Any alarm that has not yet initiated a call out sequence or an alarm still present after the snooze delay.
Phone number	A sequence of up to 30 digits used to dial a phone number and/or perform a dial escape sequence function.
Snooze delay	The time between when an alarm is acknowledged and when it begins to cause calls again.
Unlatched type	A fault which self-clears if the alarm-causing condition goes away.
DTMF	<u>D</u> ual <u>T</u> one <u>M</u> ulti <u>F</u> requency, the standard analog tone format used to represent the digits on a telephone keypad.
PSTN	<u>P</u> ublic <u>S</u> witched <u>T</u> elephone <u>N</u> etwork, also referred to as "POTS", i.e. plain old telephone system.

APPENDIX C: FCC Requirements

This equipment complies with Part 68 of the FCC rules and the requirements adopted by the ACTA. On the side of the *D51T* metal case is a label that contains, among other information, a product identifier in the format US:AAAEQ##TXXXX. If requested, this information must be provided to the telephone company.

A plug and jack used to connect this equipment to the premises wiring and telephone network must comply with the applicable FCC Part 68 rules and requirements adopted by the ACTA. A compliant telephone cord and modular plug is provided with this product. It is designed to be connected to a compatible modular jack that is also compliant. See installation instructions for details.

The REN is useful to determine the number of devices that may be connected to a telephone line. Excessive RENs on a telephone line may result in the devices not ringing in response to an incoming call. In most but not all areas, the sum of RENs should not exceed five (5.0). To be certain of the number of devices that may be connected to a line, as determined by the total RENs, contact the local telephone company. The REN for this product is part of the product identifier that has the format US:AAAEQ##TXXXX. The digits represented by ## are the REN without a decimal point (e.g., 03 is a REN of 0.3).

If the *D51T* causes harm to the telephone network, the telephone company will notify you in advance that temporary discontinuance of service may be required. But if advance notice isn't practical, the telephone company will notify the customer as soon as possible. Also, you will be advised of your right to file a complaint with the FCC if you believe it is necessary.

The telephone company may make changes in its facilities, equipment, operations or procedures that could affect the operation of the equipment. If this happens the telephone company will provide advance notice in order for you to make necessary modifications to maintain uninterrupted service.

If trouble is experienced with the *D51T*, please contact **MICROTEL** service at 1-225-303-0436 for information on obtaining service or repairs. If the equipment is causing harm to the telephone network, the telephone company may request that you disconnect the equipment until the problem is resolved.

Refer to Chapter 4 - Maintenance/Troubleshooting, for user-serviceable procedures.

Connection to party line service is subject to state tariffs. (Contact your state public utility commission or corporation commission for information.)

APPENDIX D: D51T Command Summary

*00		Report system status
*01	**01~	Voice system name (10 seconds)
*02	**02nn	Answer Delay (00 - 99 rings)
*03	**03nn	Access Code (00 = Disabled)
*04	**04HH	Snooze Delay (HH = 00 - 99 Hours)
*05		Recites vocabulary&firmware version
*06	**060/1/2	Control local output

*c1	**c1~	Fault c voice name
*c2	**c2SS	Fault c delay (00 - 99 Seconds)
*c3	**c3l/0	Fault c alarm configuration
*c4	**c4l/0	Fault c Return-To-Normal config
*c5	**c5nn	Fault c Alarm Set Point

*8n	**8np**	Telephone n (n = 1 to 4)
-----	---------	--------------------------

Phone Number Escape Codes		
*0		Tone dial (default)
*1		Pulse dial
*2		2 second pause
*3		Dial numeric pager, wait for answer
*4		Auto acknowledge this call if answered
5		Dial ''
*6		Dial '#'

~		speech (# while recording - mic cut off)
nn		two digit numeric value (00-99)
SS		time value in Seconds format
c		fault input channel number 1-5 (5=pf)
p		0-30 digit phone number, with escape codes



MICROTEL
 Technical Support &
 Service
 225/303-0436

APPENDIX E: Mechanical Dimensions

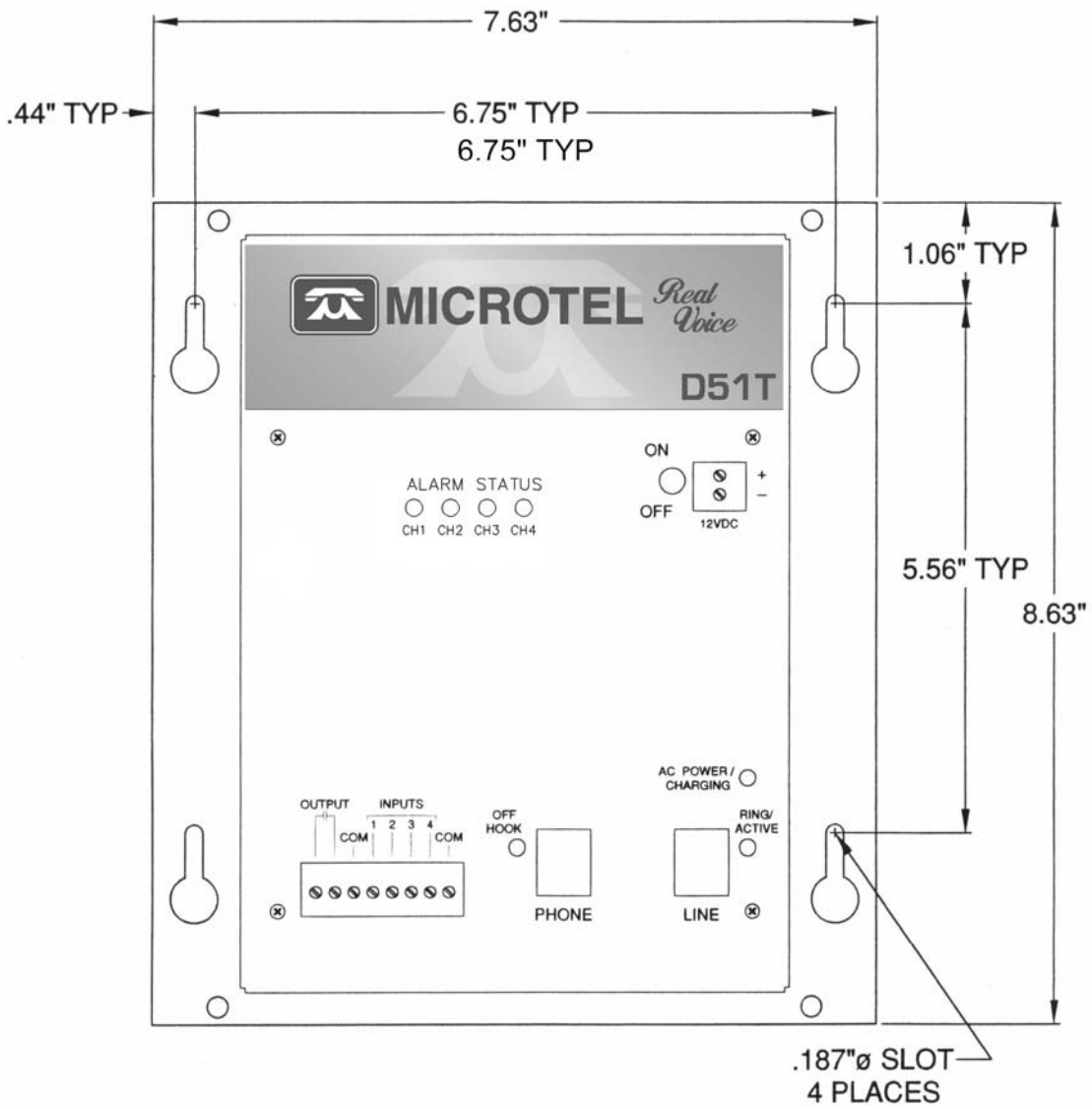

Figure 4 Mounting Dimensions